

Documentation

Electric Flat Lift model TS750

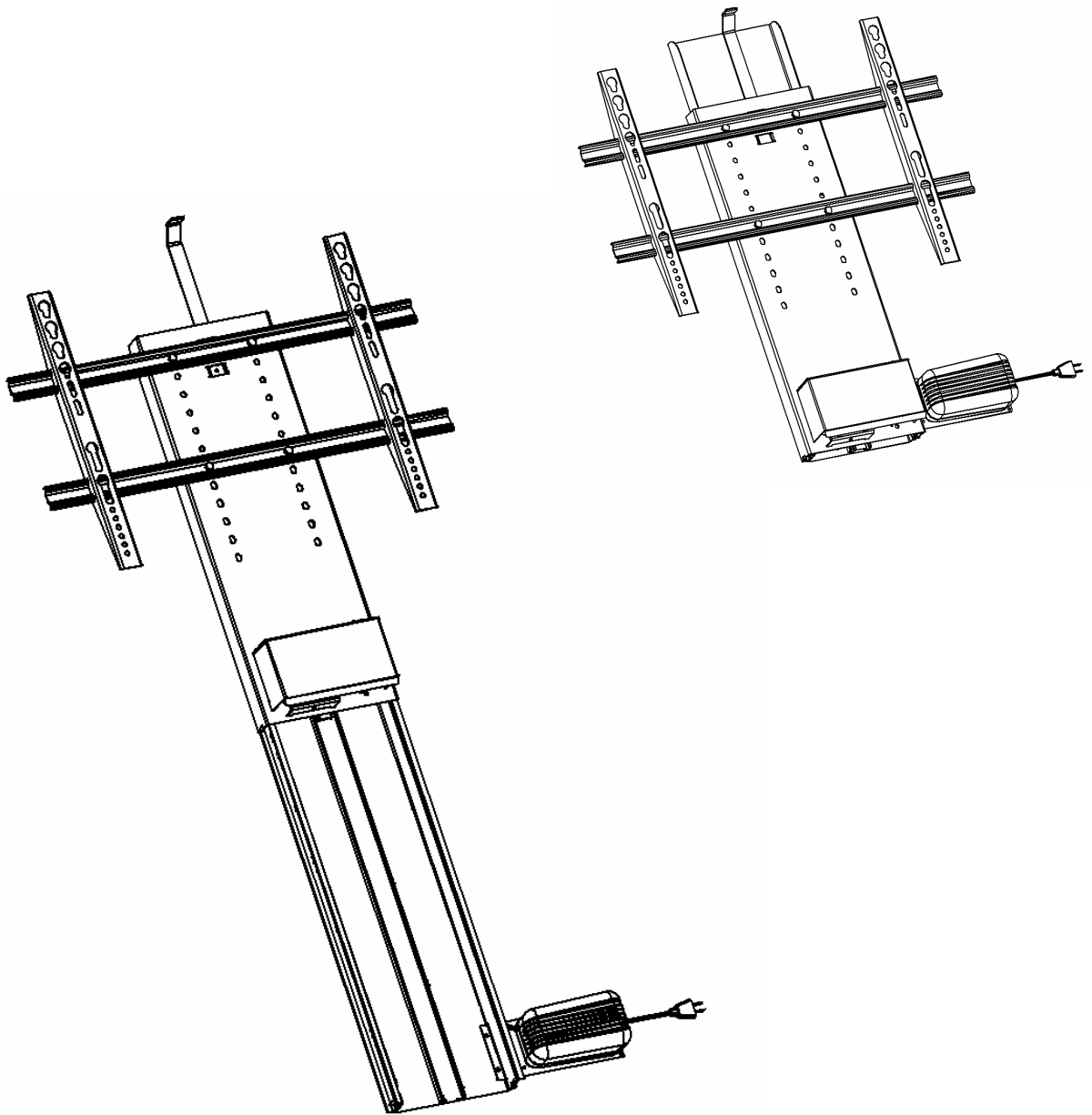
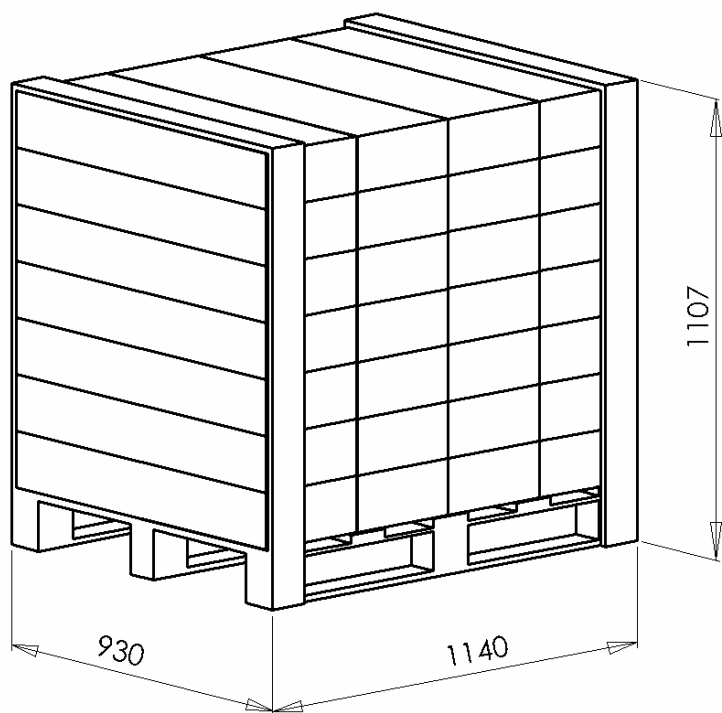

Table of contents

Packing details	page 3
Main measures and specifications	page 4
Mounting measures	page 5
Assembly and use	page 6
Component specifications	page 7

Packing details



28 pcs.

558 kg

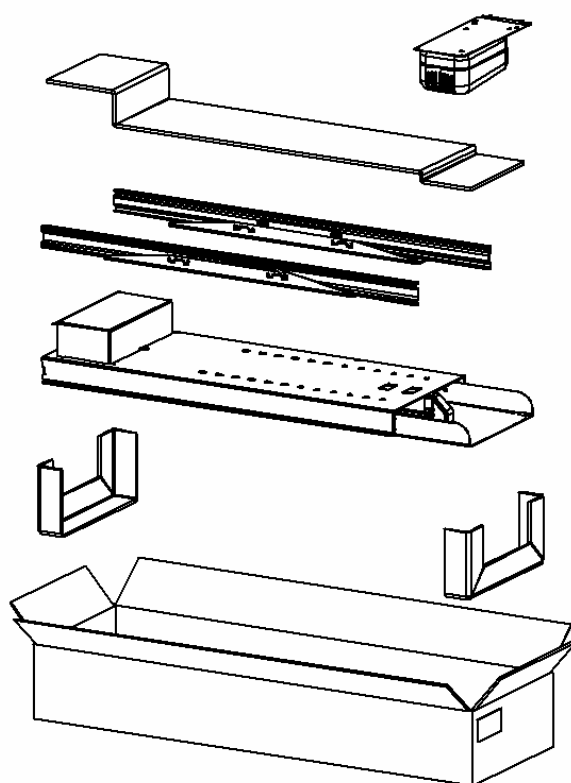

19,9 kg

Main measures and specifications

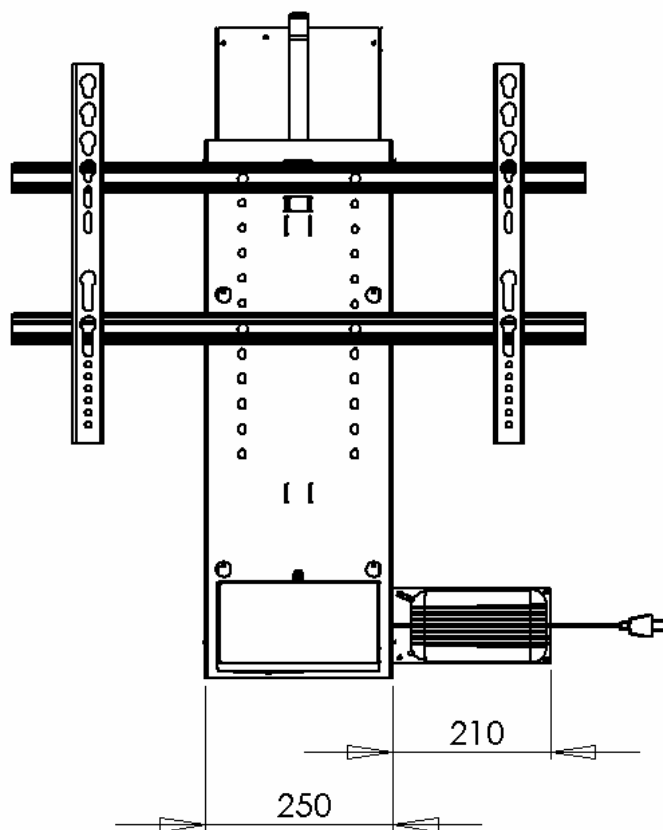
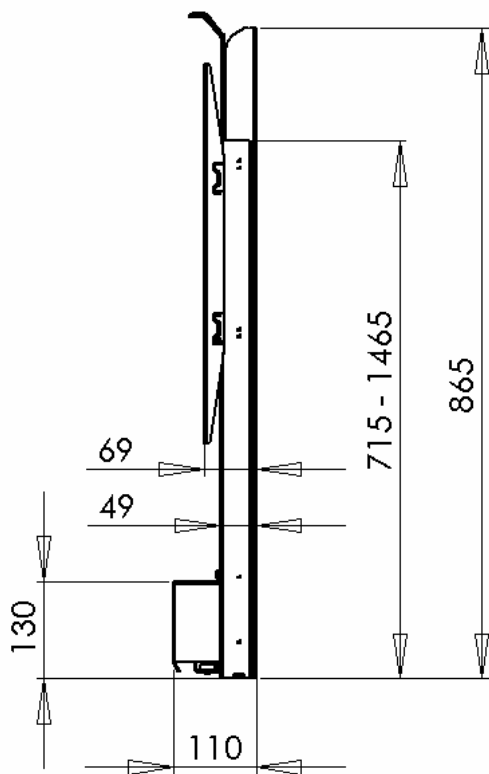

Stroke	750 mm
Lifting capacity	150 kg
Speed	28 mm/sec

If further documentation needed, please ask your dealer for dwg documentation for the different kind of models.

Mounting measures

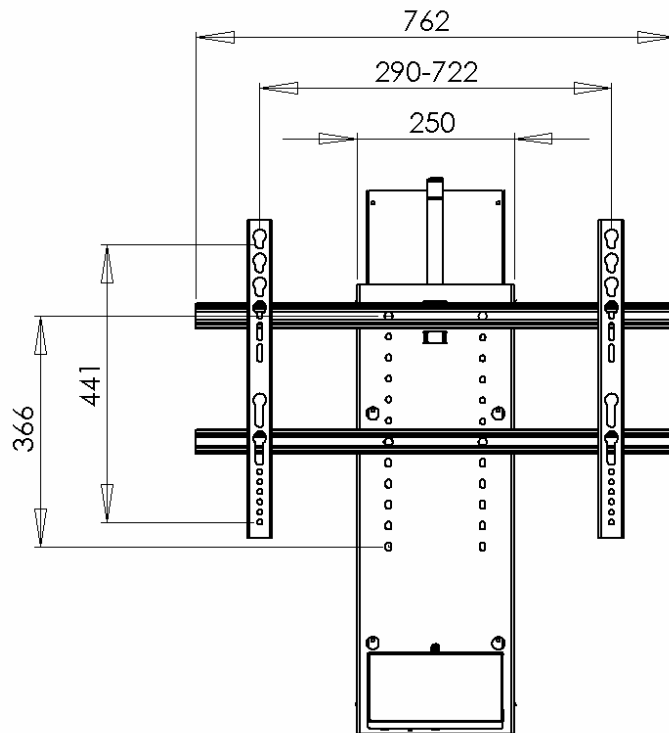
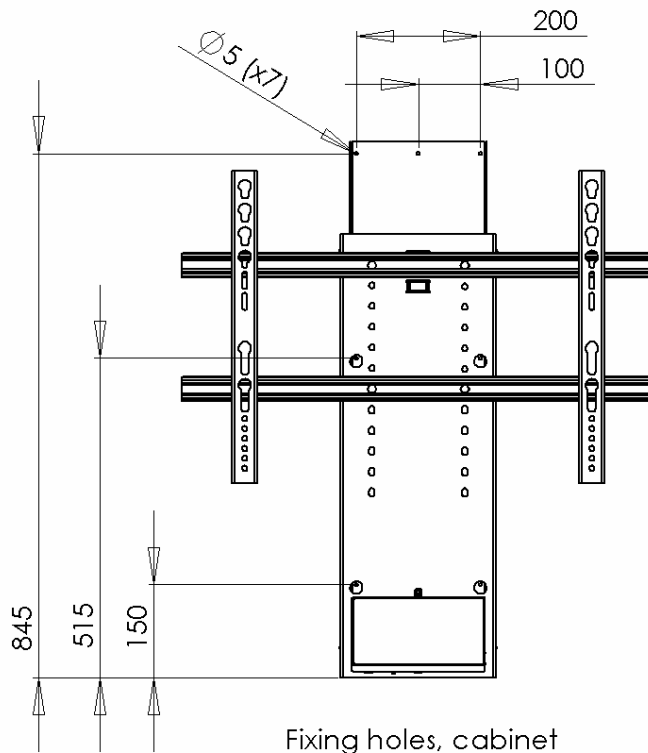

Main measures, Plasma/LCD mounting

Assembly and use

After installation of the mechanism, the electrical components can be connected. All wires have DC jacks and since using different types (size- male/female) only the correct connection will be possible to make.

Along with all products a “Direction for assembly and use” is delivered where all needed information’s about the assembly will be accessible.

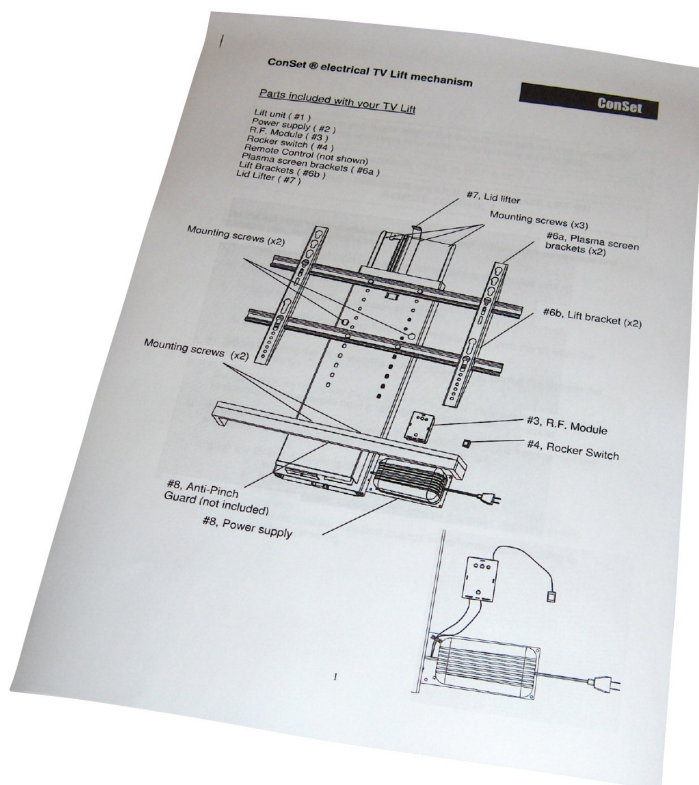

The mechanism now will be possible to operate up and down using the supplied remote unit - RF. Pushing “+” and the lift will expand. At the side of the remote a small switch is located. By switching this the “+” and “-“ will not be possible to use (safety reasons).

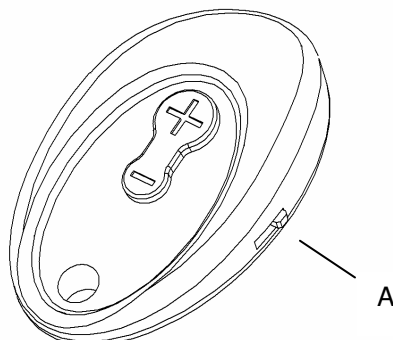

Component specifications

Metal sheet parts:	St 37-2
Gear parts:	St 70-2
Gear motor:	Bosch no. 0 390 257 685
Power supply:	60 W AC Power Transformer Consumption: 60 Watts; Standby: 0,01 Watts
Plastic components:	PEHD, PA6
Surface treatment	Visible metal parts powder coated in "alu" colour Non visible metal parts are surface treated (e.g. zinc plated)
Remote system	RF signal operated (Radio frequency)